



INLINE CAUSTIC DILUTION



- Suitable for all grades.
- Simplified on-demand process.
- Process runs in either manual or automatic, unmanned, mode.
- Dual analyzers – for process control, and for concentration verification and reporting.
- Optional temperature controls to prevent precipitation

INLINE CAUSTIC DILUTION

Flow diagrams of three typical versions of the inline caustic dilution module

LEWA caustic dilution module
eco version

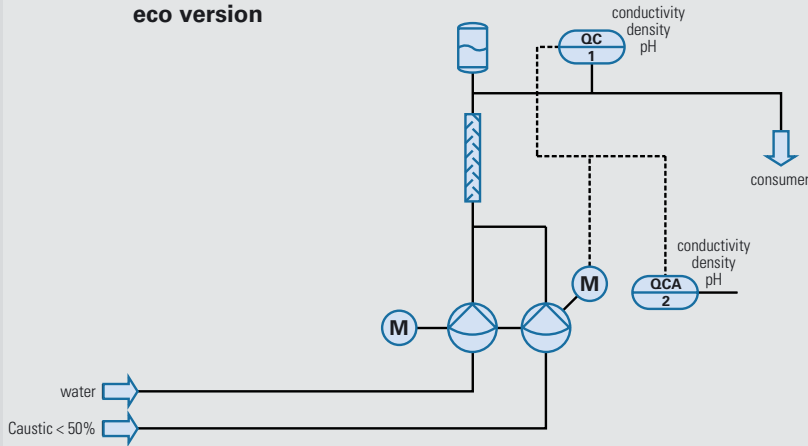

LEWA caustic dilution module
low concentration version

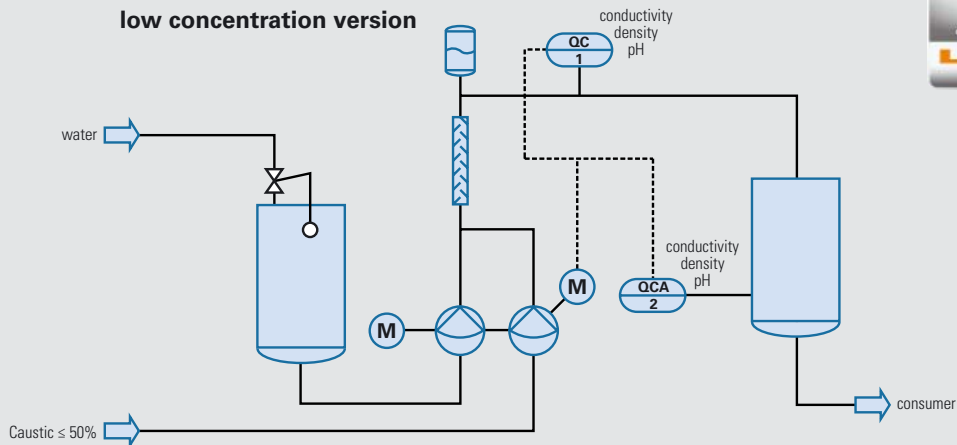

LEWA caustic dilution module-
high concentration version

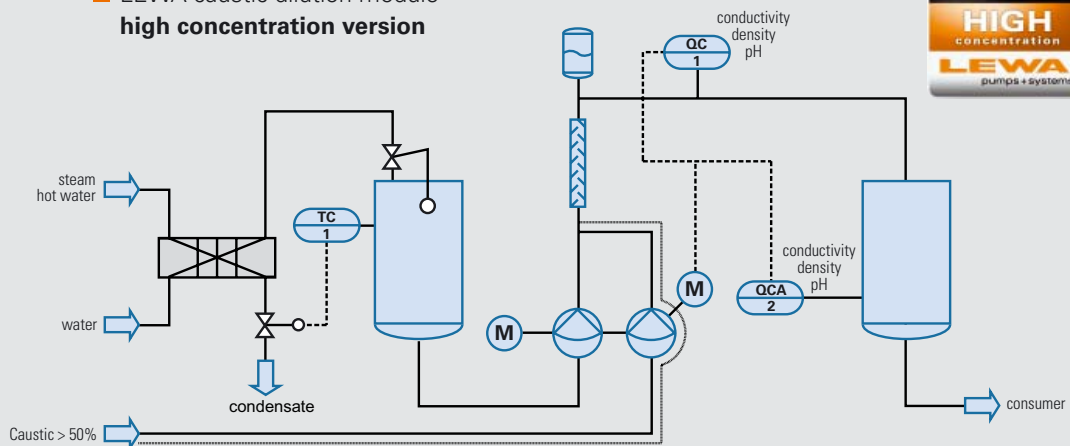

Customized layout is available too.

INLINE CAUSTIC DILUTION

Two typical versions with or without the inline caustic dilution module

without LEWA caustic dilution module

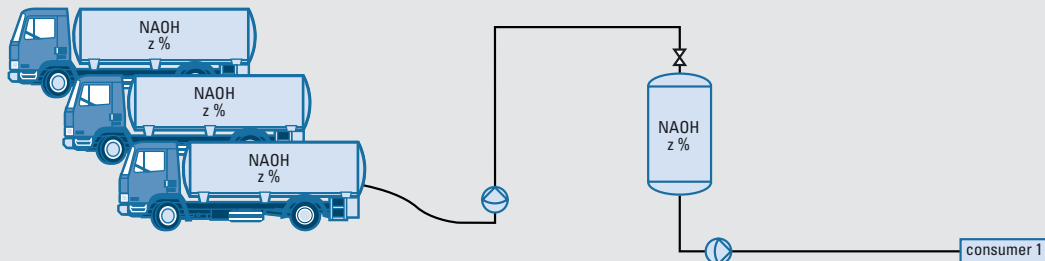

with LEWA caustic dilution module

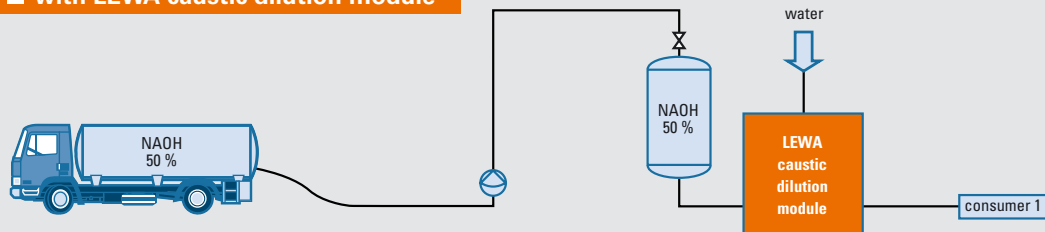

without LEWA caustic dilution module

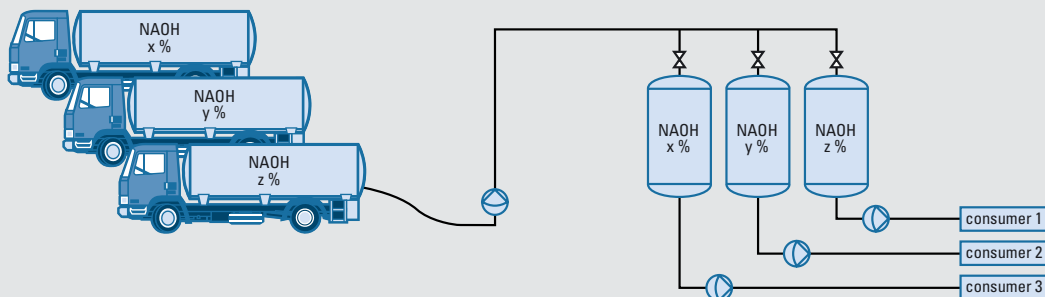

with LEWA caustic dilution module

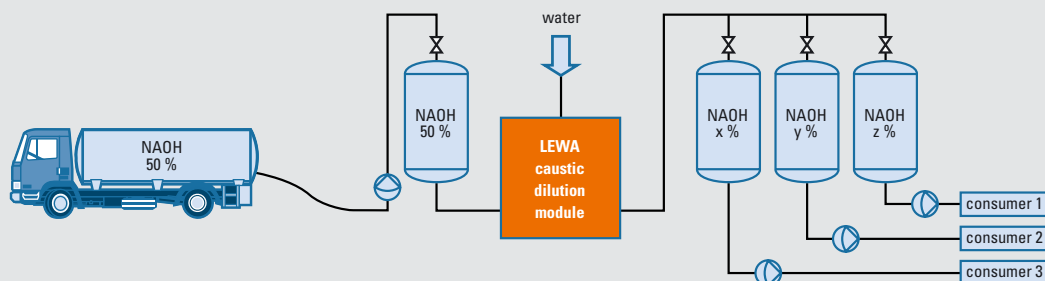

Your benefits:

- Save costs (ask for calculations)
- More independence
- More flexibility in production
- Much longer supply depot

INLINE CAUSTIC DILUTION

Typical analyzer ranges:

■ Density of aqueous solution of Sodium Hydroxide (NaOH)

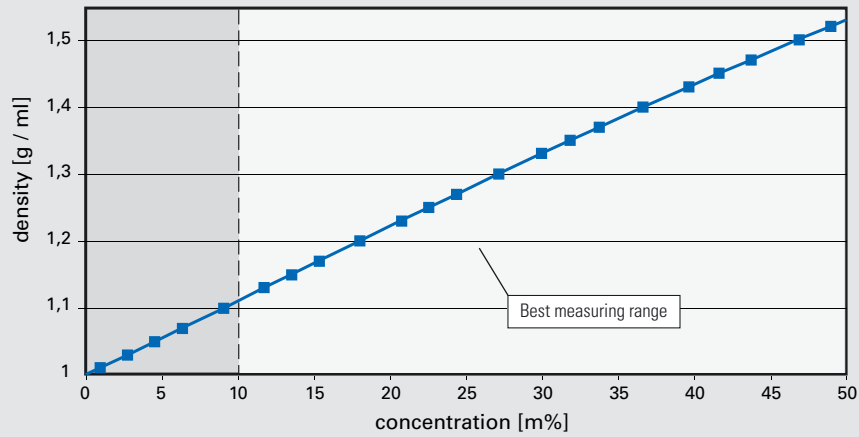

■ Conductivity of aqueous solution of Sodium Hydroxide (NaOH)

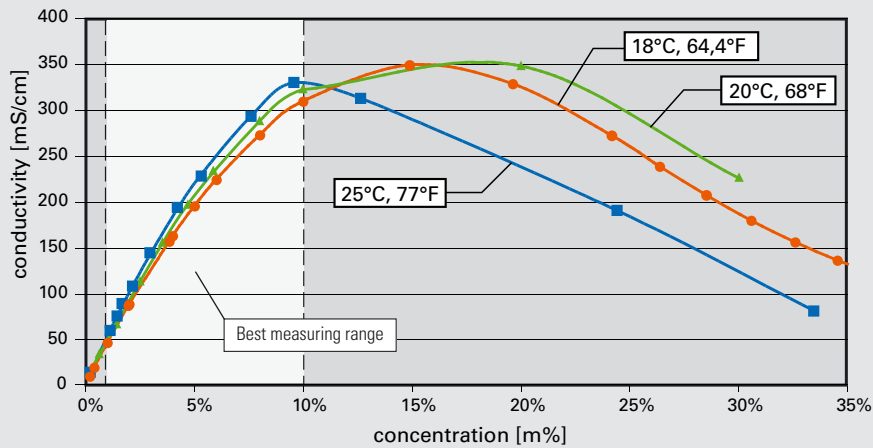

■ pH value of aqueous solution of Sodium Hydroxide (NaOH)

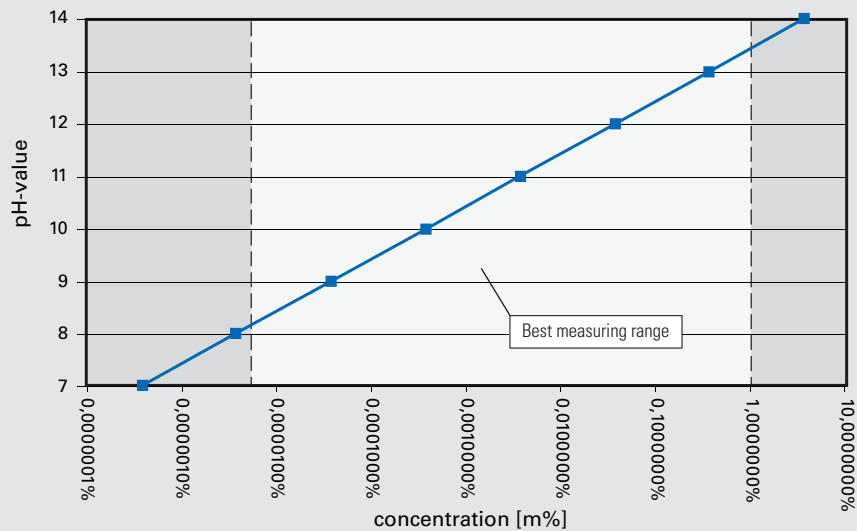

INLINE CAUSTIC DILUTION

Caustic solutions such as Sodium hydroxide, lye and caustic soda are commercially available, typically in concentrations of 50% and above. The LEWA inline caustic dilution module is well suited for any of these solutions. The dilution of caustic is a controlled process that eliminates precipitation and/or excessive exothermic reactions. The knowledge and experience gained by LEWA is behind the development of proportioning equipment that meets your most stringent process needs.

Typical applications:

- Water treatment
- Food processing
- Soap and detergent manufacturing
- Mining
- Glass processing
- Vegetable oil processing
- Chemical manufacturing (pH-Control)
- Disinfectants
- Sodium hypochloride

customer:		COMPARISON OF COSTS INLINE DILUTION OF CAUSTIC					
BASIC DATA							
concentration of caustic needed:	4,00	%					
consumption of caustic 10% per year:	250.000	kg					
volume of vessel:	20,00	m ³					
no of tank refillings with caustic 10%:	12,50	tanks					
volume of water per year:	240.000,00	kg water					
volume of sodium hydroxide per year:	10.000,00	kg of sodium hydroxide					
concentration of caustic to buy:	50,00	%					
production capacity of LEWA caustic dilution module:	1.000	kg/h					
electrical power capacity of LEWA caustic dilution module:	8,00	kW					
consumption of caustic 50 % per year:	20.000,00	kg of caustic 50 % per year					
required tank fillings of caustic 50 % per year:	1,00	tanks					
COSTS		INSTALLATION CAUSTIC 50 %			INSTALLATION CAUSTIC 4 %		
Costs per kg caustic:	0,155	Euro			0,120	Euro	
costs per liter water:	0,010	Euro / liter					
labour costs:	40,00	Euro / hour			40,00	Euro / hour	
costs energy:	0,09	Euro / kW					
COSTS OF PRODUCTION 200000 KG CAUSTIC AT 10%							
time to prepare tank	2,00	hour	80,00	Euro	2,00	hour	1.000,00 Euro
time to work on tank	0,50	hour	20,00	Euro	0,50	hour	250,00 Euro
time for administration per tank	0,50	hour	20,00	Euro	0,50	hour	250,00 Euro
power consumption	250,00	hour	180,00	Euro			0,00 Euro
costs of water	240.000,00	liter	2.400,00	Euro			0,00 Euro
costs of caustic	0,16	Euro	3.100,00	Euro	0,12	Euro	30.000,00 Euro
DIFFERENCE							
production costs per year:			5.800,00	Euro			31.500,00 Euro
costs per kg caustic			0,02	Euro			0,13 Euro
difference per kg:			0,10	Euro			
difference per year:			25.700,00	Euro			
INVESTMENT							
Investment costs LEWA inline caustic dilution module:	52.000,00	Euro			existing		
Investment costs for add. Tank	0,00	Euro			existing		
Investment costs transfer pump	0,00	Euro			existing		
Investment costs piping	0,00	Euro			existing		
Total			52.000,00 Euro				
AMORTIZATION							
payback time	2,0	years					
benefit	25.700,00	Euro / year					

For further information please contact: