

LEWA ecoflow®

Variable eccentric pump drive

Type LDE

- Drive units
- Metering pumps

Performance

Pressure	up to 1000 bar
Flow rate	up to 10 m ³ /h per pump head
Temperature	up to 400° C



Customer advantages

- **Rod thrust:** 20 kN
- **Stroke length:** 30 mm
- **Stroke adjustment:** available with fixed stroke length or with stroke length adjustment. Setting of stroke length is carried out manually, electrically or pneumatically
- **Linear stroke adjustment** in steps of 0,01 mm via hand wheel while pump is stopped or in operation. Proven variable eccentric drive principle, that means stroke length is adjusted where it arises: at the eccentric
- **Multiplex drive units** also in different frame sizes with motor mounted horizontally. Common oil bath without radial shaft seal ring between the drive units (thus less wear parts)
- **Harmonic plunger motion** also at partial stroke
- **API 675 specification** is met
- **Differing stroke rates** make it possible to meet requirements for different fluids and process conditions
- **Long life** due to solid construction, best materials, oil bath lubrication, weather- and splash protection

■ Simple operation, easy maintenance

- **Pump head types:** plunger- and diaphragm pump heads can be mounted
- **Drive:** AC and DC motors, frequency inverter possible
- **Attachable instruments:** contactor

Method of operation

The drive shaft turns the **eccentric** via the **worm gear** and the **hollow shaft**. The **connecting rod** converts the rotary motion of the eccentric into a reciprocating motion of the **plunger rod**. The stroke length for the displacer movement is set (with the pump stopped or in operation) through radial shifting of the **eccentric**. For this the **sliding shaft** is axially shifted via the **adjusting spindle**. The axial movement of the sliding shaft is converted into a radial movement of the **eccentric** via the skew-slotted groove in the **hollow shaft**.

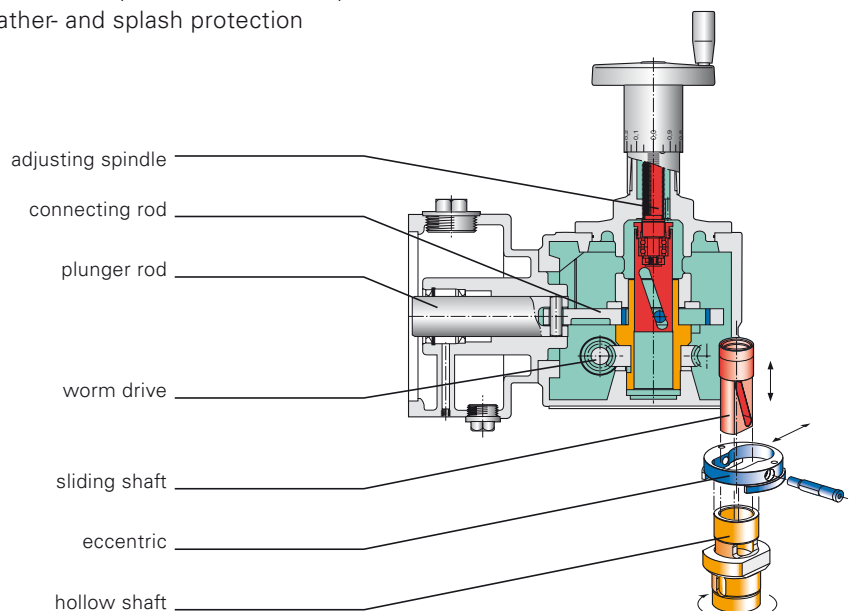

Performance data

Standard plunger ø [mm]	Q _{theor.} [l/h] ¹⁾ Calc. flow rate per pump head at max. stroke length and stroke frequency n [min ⁻¹]					Permissible operating pressure of standard pump heads [barg]				
						Diaphragm pump heads		Plunger pump heads		
	72	113	141	170	225	Type	M 900	M 200	M 500	K
						Model ³⁾	3	2, 3		2, 3
12	14,66	23,00	28,70	34,61	45,80		---	1000	---	---
16	26,06	40,90	51,03	61,52	81,43		---	700	---	500
17	29,42	46,17	57,61	69,46	91,93		400	---	---	---
20	40,72	63,90	79,73	96,13	127,2		---	500	---	500
21	44,89	70,45	87,91	106,0	140,3		400	---	---	---
25	63,62	99,84	124,6	150,2	198,8		400	407	---	407
30	91,61	143,8	179,4	216,3	286,3		280	198	---	283
34	117,7	184,7	230,4	277,8	367,7		218	---	---	---
36	131,9	207,0	258,3	311,5	412,2		---	196	---	196
38	147,0	230,7	287,8	347,0	459,3		174	---	---	---
42	179,6	281,8	351,6	423,9	561,1		142	---	---	---
44	197,1	309,3	385,9	465,3	615,8		---	107	---	132
46	215,4	338,0	421,8	508,5	673,1		118	---	---	---
52	275,2	432,0	539,0	649,9	860,1		91,7	94,2	---	94,2
58	342,4	537,4	670,6	808,5	1070		73,2	---	---	---
60	366,4	575,1	717,6	865,2	1145		---	50,0	---	70,7
66	443,4	695,9	868,3	1047	1386		56,0	---	---	---
70	498,8	782,8	976,7	1178	1559		---	50,0	---	52,0
74	557,4	874,8	1092	1316	1742		44,0	---	---	---
82	684,4	1074	1340	1616	2139		35,4	---	---	---
85	735,4	1154	1440	1736	2298		---	---	---	35,2
92	861,5	1352	1687	2034	2692		27,6	---	---	---
100	1018	1597	1993	2403	3181		---	---	---	25,5
104	1101	1728	2156	2599	3440		21,0	---	---	---
116	1370	2150	2682	3234	4280		16,4	---	---	---
120	1466	2300	2870	3461	4580		---	---	17,7	17,7
140	1995	3131	3907	4711	6234		---	---	13,0	13,0
175	3117	4892	6105	7360	9741		---	---	8,3	8,3

1) Q_{theor.} from stroke volume x stroke frequency. Q_{off.} (= Q_{theor.} x η_p) is stated in technical data sheet. For multiplex pumps, determine total metered flow by multiplying by the number of pump heads

2) 2 = 13 % Cr steel; 3 = stainless steel CrNiMo 18/10/2; other materials, e.g. Hastelloy to special order

3) Standard pump head connections depending on pump head size: internal thread to DIN or NPT resp. flanges to DIN or ANSI

Dimensions

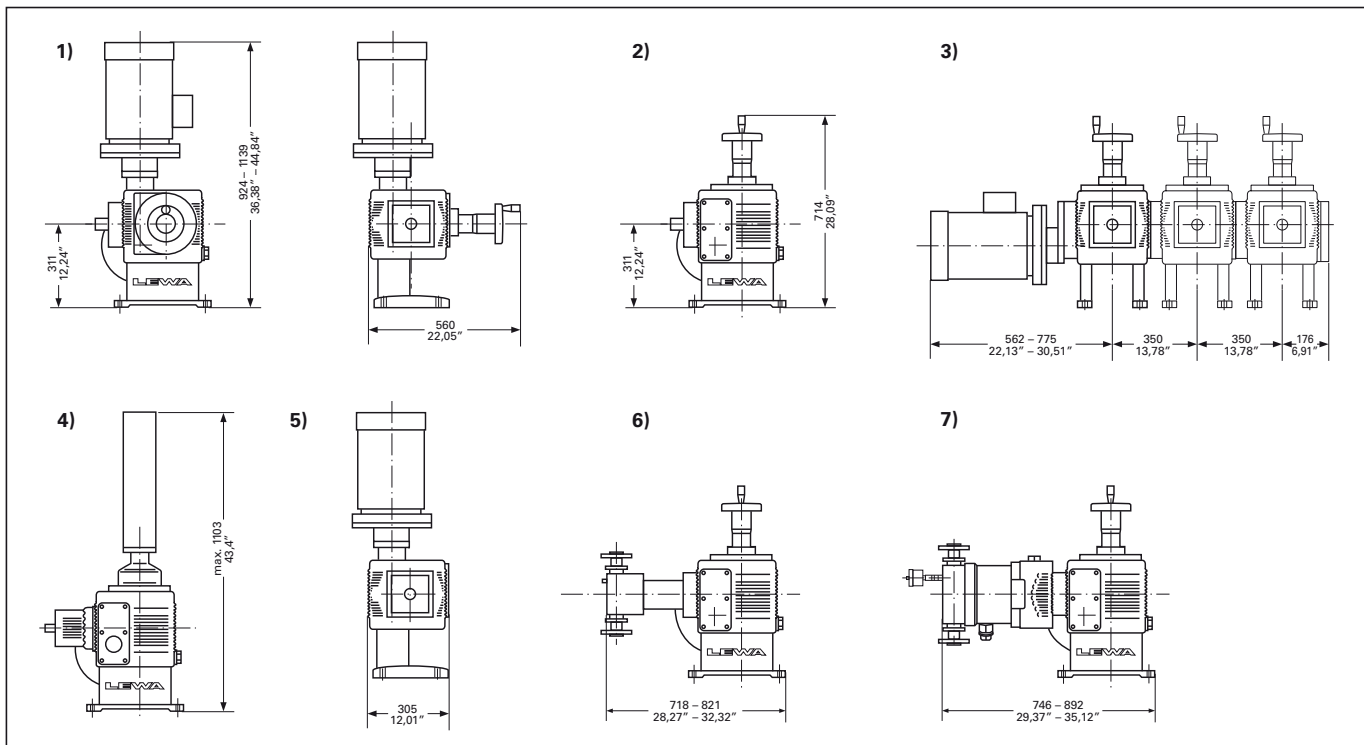

Drive units

- 1) Simplex drive unit with manual stroke adjustment/motor mounted vertically
- 2) Simplex drive unit with manual stroke adjustment/motor mounted horizontally
- 3) Multiplex drive unit with manual stroke adjustment/motor mounted horizontally
- 4) Simplex drive unit with electric or pneumatic stroke adjustment/motor mounted horizontally
- 5) Simplex drive unit without stroke adjustment/motor mounted vertically

Pumps

- 6) Plunger pump
- 7) Diaphragm pump

A MEMBER OF **NICKISO**
LEWA
 pumps + systems

Creating Fluid Solutions

Germany / Headquarters

LEWA GmbH

Ulmer Str. 10
 71229 Leonberg
 Phone +49 7152 14-0
 Fax +49 7152 14-1303
 lewa@lewa.de
 www.lewa.de