

LEWA ecoflow®

Variable eccentric pump drive

Type LDG

- Drive units
- Process pumps

Performance

Pressure	up to 1200 bar
Flow rate	up to 25 m³/h per pump head
Temperature	up to 400°C

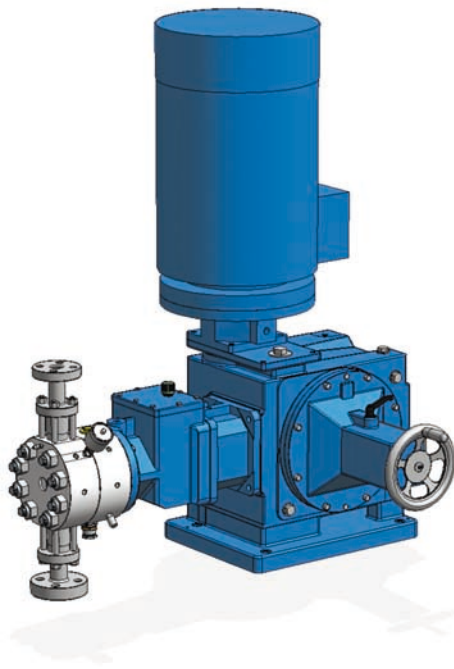

Customer advantages

- **Rod thrust:** 35 kN
- **Stroke length:** 60 mm
- **Stroke adjustment:** available with fixed stroke length or with stroke length adjustment. Setting of stroke length is carried out manually or electrically
- **Linear stroke adjustment** in steps of 0,05 mm via hand wheel while pump is stopped or in operation. Proven variable eccentric drive principle, that means stroke length is adjusted where it arises: at the eccentric
- **Multiplex drive units** also in different frame sizes with motor mounted horizontally. Common oil bath without radial shaft seal ring between the drive units (thus less wear parts)
- **Harmonic plunger motion** also at partial stroke
- **API 675 specification** is met
- **Differing stroke rates** make it possible to meet requirements for different fluids and process conditions
- **Long life** due to solid construction, best materials, oil bath lubrication, weather- and splash protection
- **Simple operation, easy maintenance**

- **Pump head types:** plunger- and diaphragm pump heads can be mounted
- **Drive:** three phase motor, frequency inverter possible
- **Attachable instruments:** contactor

Method of operation

The drive shaft turns the **eccentric** via the **worm gear** and the **hollow shaft**. The **connecting rod** converts the rotary motion of the eccentric into a reciprocating motion of the **plunger rod**. The stroke length for the displacer movement is set (with the pump stopped or in operation) through radial shifting of the **eccentric**. For this the **sliding shaft** is axially shifted via the **adjusting spindle**. The axial movement of the sliding shaft is converted into a radial movement of the **eccentric** via the skew-slotted groove in the **hollow shaft**.

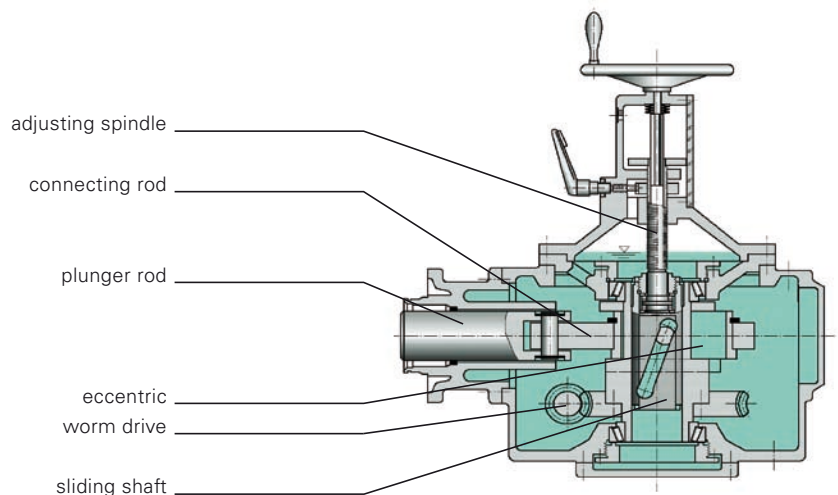

Performance data

Standard plunger ø [mm]	Q _{theor.} [l/h] ¹⁾ Calc. flow rate per pump head at max. stroke length and stroke frequency n [min ⁻¹]						Permissible operating pressure of standard pump heads [barg]						
	100	72	113	141	170	225	Type		Diaphragm pump heads				
							Model ³⁾	M9	M5/M2				
							Material ²⁾	3	2, 3				
16	72,4	52,1	81,8	102,1	123,0	162,9	---	1200,0					
20	113,1	81,4	127,8	159,5	192,3	254,5	---	1000,0					
25	176,7	127,2	199,7	249,2	300,4	397,6	---	710,0					
27	206,1	148,4	232,9	290,6	350,4	463,8	500,0	---					
28	221,7	159,6	250,5	312,6	376,8	498,8	500,0	---					
29	237,8	171,2	268,7	335,3	404,2	535,0	500,0	---					
30	254,5	183,2	287,6	358,8	432,6	573,0	493,0	---					
32	289,5	208,5	327,2	408,2	492,2	651,0	310,0	350,0					
34	326,9	235,3	369,3	460,9	556,0	735,0	310,0	---					
36	366,4	263,8	414,1	517,0	623,0	824,0	310,0	344,0					
38	408,0	294,0	461,0	576,0	694,0	919,0	306,0	---					
42	499,0	359,0	564,0	703,0	848,0	1122,0	250,0	---					
44	547,4	394,1	618,6	771,8	930,6	1232,0	228,0	---					
46	598,3	430,8	676,1	843,6	1017,0	1346,0	208,0	---					
48	651,4	469,0	736,1	918,5	1107,0	1466,0	191,0	---					
50	706,9	508,9	798,8	996,7	1202,0	1590,0	176,0	---					
52	764,5	550,5	863,9	1078,0	1300,0	1720,0	162,0	---					
54	824,5	593,6	931,7	1162,5	1402,0	1855,0	150,0	---					
58	951,1	684,8	1075,0	1341,0	1617,0	2140,0	130,0	---					
62	1087,0	782,5	1228,0	1533,0	1848,0	2445,0	113,0	---					
66	1232,0	886,8	1392,0	1737,0	2094,0	2771,0	99,8	---					
70	1385,0	997,5	1566,0	1953,0	2355,0	3117,0	88,4	---					
74	1548,0	1115,0	1750,0	2183,0	2632,0	3484,0	78,9	---					
78	1720,0	1239,0	1944,0	2425,0	2924,0	3870,0	70,7	---					
82	1901,0	1369,0	2148,0	2681,0	3232,0	4278,0	63,8	---					
85	2043,0	1471,0	2308,0	2880,0	3473,0	4596,0	---	61,7					
92	2393,0	1723,0	2704,0	3374,0	4068,0	5385,0	---	52,7					
100	2827,0	2036,0	3195,0	3987,0	4807,0	6362,0	---	44,6					
120	4072,0	2931,0	4601,0	5741,0	6922,0	9161,0	---	30,9					
140	5542,0	3990,0	6262,0	7814,0	9421,0	12469,0	---	22,7					
175	8659,0	6234,0	9785,0	12209,0	14720,0	19483,0	---	14,6					
200	11310,0	8143,0	12780,0	15947,0	19227,0	25447,0	---	11,1					

1) Q_{theor.} from stroke volume x stroke frequency. Q_{eff.} (= Q_{theor.} x η_p) is stated in technical data sheet. For multiplex pumps, determine total metered flow by multiplying by the number of pump heads

2) 2 = 13 % Cr steel; 3 = stainless steel CrNiMo 18/10/2; other materials, e.g. Hastelloy to special order

3) Standard pump head connections depending on pump head size: internal thread to DIN or NPT resp. flanges to DIN or ANSI

A MEMBER OF **NIKKISO**
LEWA
 pumps + systems

Creating Fluid Solutions

Germany / Headquarters

LEWA GmbH

Ulmer Str. 10

71229 Leonberg

Phone +49 7152 14-0

Fax +49 7152 14-1303

lewa@lewa.de

www.lewa.de