

LEWA EcoPrime[®] LPLC

With integrated buffer in-line dilution.





LEWA EcoPrime LPLC. With integrated buffer in-line dilution option.

Providing analytical performance at pilot and production scale and highly configurable, LEWA EcoPrime systems provide a complete low-pressure liquid chromatography solution with integrated buffer in-line dilution option.

LEWA EcoPrime is an advanced downstream solution designed to optimize biopharmaceutical pilot and production processes. Incorporating state-of-the-art fluid management technology, and proprietary flow path design, this new platform combines innovative hygienic metering pumps with digital LEWA intellidrive technology to deliver the industries' highest accuracy. With the buffer in-line dilution (BID) option integrated on the same skid, LEWA EcoPrime can significantly reduce equipment and tankage footprint and capital expenditure.

With more than 10,000 LEWA pumps used on chromatography systems since the 1980s, LEWA is globally respected as a proven supplier of reliable downstream technology.

Take your chromatography to the next level

- For difficult separations which require precise peak separation, LEWA EcoPrime's best-in-class gradient accuracy enables higher productivity while maintaining required purity.
- The broad flow range of each EcoPrime system allows the use of one system for several processes or multiple projects.
- Enhanced buffer in-line dilution enables use of concentrated buffers and significantly frees up more space in the production area.
- Excellent reproducibility across batches is achieved through the precision of the digital control technology of the system, piping design and pumps themselves.
- LEWA EcoPrime user adaptable software is designed specifically for the GMP manufacturing environment.

Configuration in accordance with customer requirements

From among 20 standard options, you can choose the functions that correspond exactly to your specific process requirements. By using the platform design, LEWA provides the consistency of a standard system along with the flexibility needed to satisfy your specific requirements.

Options

Third pump to expand BID capability, includes 2 inlets
Additional inlet valves for additional 3rd pump
Pre-column analytics (pH and conductivity)
Pressure control at the column outlet
Flow meter for each pump
Additional inlet valves for primary pumps
Bubble trap with level sensors and drain
Static mixer
Pre-pump air sensors for all pumps
Cleaning in Place (CIP) includes the inlet and outlet manifolds
Blow-down (includes regulator, filter and valves)
Additional outlet valves
Pre-column filter assembly
Drainability

Advantages

Simultaneous buffer dilution is possible
Two additional inlets for more flexibility
Provides pH and conductivity measurements
Prevents outgassing in the column
Flow meter for controlling and monitoring the flow rate
Adds 2 or 4 additional valves to accommodate more feed streams
Prevents air from entering at the column
Improves the mixing of different process fluids
Detects air at the inlet of the pump
Removable manifolds to facilitate cleaning the system
Enables blow down to dry the system
Adds 2 or 6 more outlet valves to accommodate more fractions
Removes particulates from incoming process fluids
Facilitates fully draining the system

Additional options include a UPS connection, an additional PLC network card and DeltaV control options.

LEWA EcoPrime.

The advantages at a glance.

Analytical performance at pilot and production scale

The efficiency of LEWA EcoPrime achieves laboratory accuracy – on both the pilot scale and the production scale. The system enables high-precision gradients and provides accuracy and reproducibility with a flow deviation less than $\pm 1\%$.

Increases product yield and purity

Increased product yield, better quality, fewer fractions and excellent reproducibility across batches – these are the advantages of the exclusive LEWA intellidrive pump technology with digital fluid control and a highly optimized piping design.

Broader flow range for maximum flexibility

The broad flow range of the systems makes it possible for customers to use a variety of column diameters on a single system. The system can take over the function of two conventional skids and one additional in-line dilution system and can be used effortlessly in process development and for pilot or production processes. The advanced design creates space in the production area and thereby reduces costs.

Increased accuracy and reproducibility leads to improved yield and purity

System design makes the difference in gradient performance

LEWA EcoPrime vs Conventional System

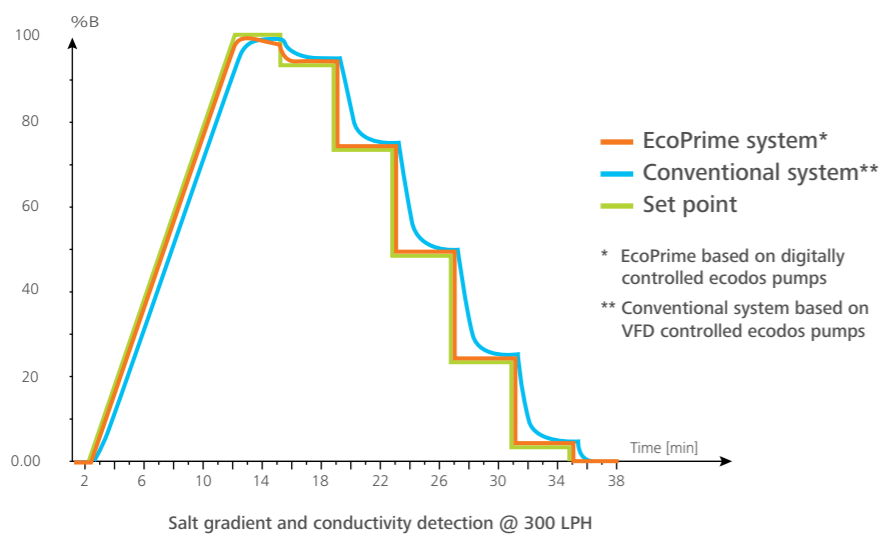

Individually configurable software

The architecture of LEWA EcoPrime software enables it to be individually adapted by the user. It is recipe driven with configurable sequences. It uses an intuitively designed HMI, standard batch reporting and a Historian for trending data.

Reducing investment and operating costs with integrated buffer in-line dilution

Using concentrated buffers, LEWA EcoPrime buffer in-line dilution (BID) option will significantly reduce tank footprint and free up space, lowering your operation expenses. Chromatography and buffer in-line dilution are integrated thus combining two unit operations into a single system.

LEWA EcoPrime LPLC.

Features for individual requirements.

Coriolis flow meter technology

Blow-down and full drainability options

Exclusive digital motors with controller

Optional buffer in-line dilution

LEWA ecodos hygienic pumps



Interactive HMI
 Control panel characteristics 19" (48 cm) IP 65 control cabinet
 User adaptable software

Pre-filter and bubble trap options

Up to 10 outlet valves

Pre-/Post-column analytics

Select multiple inlet valves arrangements

We configure entirely according to your needs using 20 different options.

LEWA EcoPrime LPLC.

Flow schematic for standard platform.

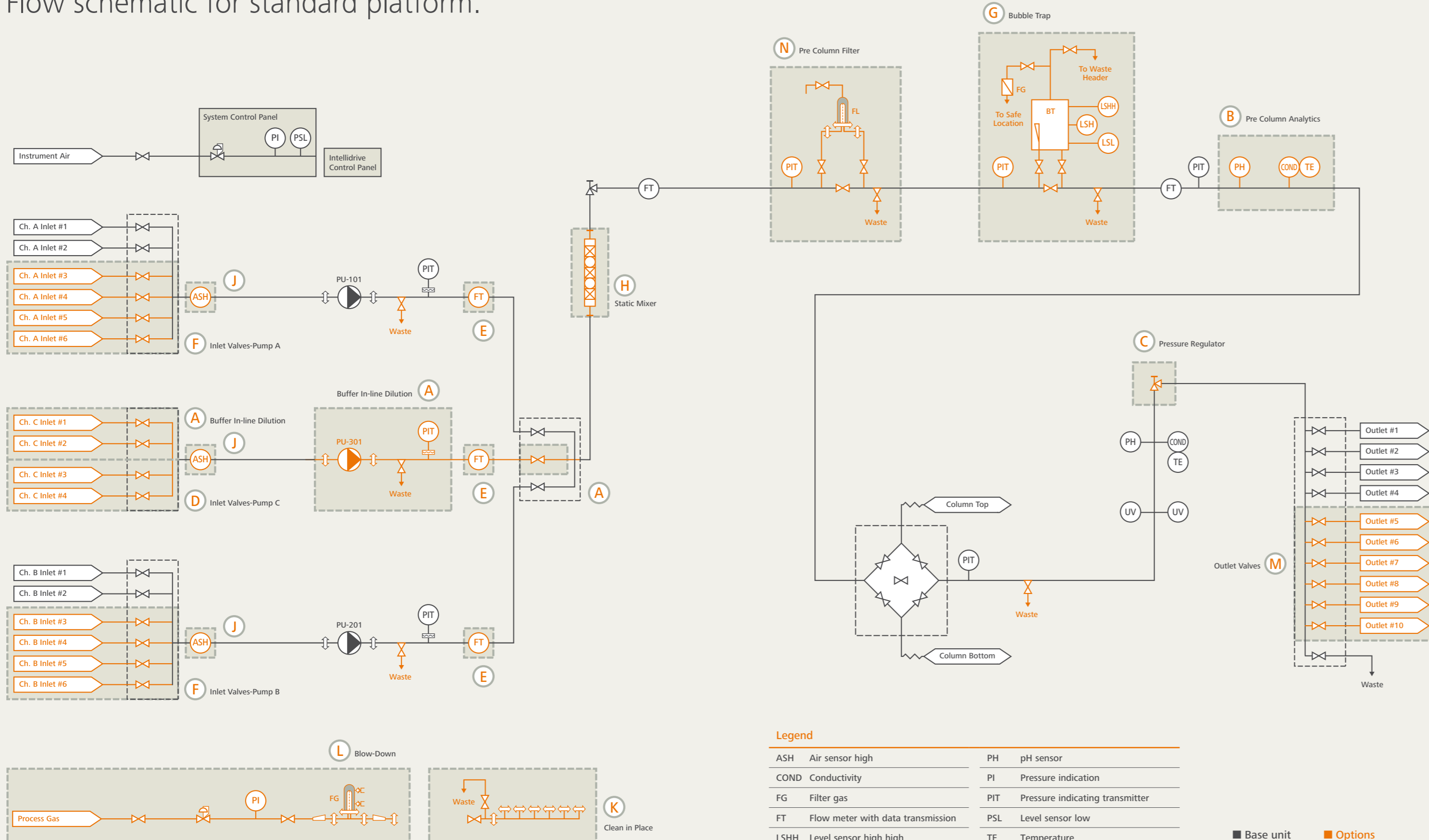

Legend

ASH	Air sensor high	PH	pH sensor
COND	Conductivity	PI	Pressure indication
FG	Filter gas	PIT	Pressure indicating transmitter
FT	Flow meter with data transmission	PSL	Level sensor low
LSHH	Level sensor high high	TE	Temperature
LSH	Level sensor high	UV	UV sensor
LSL	Level sensor low		

■ Base unit ■ Options

See the table to the right for the corresponding LEWA EcoPrime options marked by letters in the flow schematic.

LEWA EcoPrime LPLC	Model			
Base unit	EP 250	EP 500	EP 1000	EP 2000*2
Pump (LEWA ecodos model)*1	LEC (50)	LED (180)	LEE (350)	LEF (550)
Flow rate system	0.02 to 2.40 l/min	0.06 to 9.00 l/min	0.12 to 17.00 l/min	0.22 to 33.00 l/min
OD piping (pump suction side)	¾" (19.0 mm)	1" (25.4 mm)	1 ½" (38.1 mm)	2" (50.8 mm)
OD piping (pump discharge side)	⅜" (9.5 mm)	½" (12.7 mm)	½" (12.7 mm)	¾" (19.0 mm)

Standard functions – all models

Pump A inlets	2
Pump B inlets	2
System outlets	5 (4 for fractions and 1 for waste products)*3
Flow meter	1
Pressure transmitter	4
Pre-column air sensor	1
Post-column UV sensor (dual wavelength)	1
Post-column pH sensor	1
Post-column conductivity sensor	1
Pump backpressure regulator	1
Primary material of construction	Stainless steel

LEWA EcoPrime LPLC options (A-H are P&ID reference points)

Model	EP 250	EP 500	EP 1000	EP 2000*2
A Improved buffer in-line dilution – Pump C (LEWA ecodos model)*1 includes 2 inlets	LEC (50)	LED (180)	LEE (350)	LEF (550)

Options – all models (P&ID reference points)

B Pre-column analytics (pH and conductivity sensors)	1
C Column outlet pressure control	1
D Inlets pump C	2 additional valves
E Flow meter	Select 1, 2 or 3 additional
F Inlet valves for pumps A and B	Select 2 or 4 additional
G Bubble trap (includes PIT, level sensor and drain)	1
H Static mixer	1
J Pre-pump air sensors	Select 1, 2 or 3 additional
K CIP manifolds	1 inlet and 1 outlet**4
L Blow-down system (includes only regulator, filter and valves)*5	1
M Outlet valves*3	Select 2 or 6 additional fraction outlets
N Pre-column filter (includes valves, PIT, drain and vent)*5	
O Drainability (includes blow-down option)*5	

Options – all models

P UPS-ready (for UPS provided by the customer)
Q SCADA UPS
R Second PLC network card
DeltaV1:
V1 LEWA HMI, PLC and software not included; system control via PLC provided by customer
DeltaV2:
V2 LEWA HMI, PLC and software not included; LEWA provides DeltaV type 5 controller and I/O modules

*1 Triplex pumps with exclusive LEWA intellidrive technology
 *2 Currently only custom design available
 *3 Outlet valves made of PVDF
 *4 Includes blow-down option; includes block valves at 4 or more drain points
 *5 Customer provides connections if blow-down option is not ordered with O or K



LEWA EcoPrime Twin for continuous or batch chromatography

Built for the regulated environment.

Software and control system

The EcoPrime software is designed to be user-friendly and intuitive. The control software helps the user to easily navigate and manage process setup, execution and reporting. Operation is controlled by a recipe and is supported by a library of predefined sequences for all standard functions. The system is controlled by a PLC with industrial PC-based HMI as an interface and data acquisition device. The software was developed for pilot and process GMP environments, and enables 21 CFR Part 11 compliance.

Standards and regulatory requirements

The design and construction of LEWA EcoPrime meets the following standards, assuring a safe, ergonomic system capable of producing products within Food and Drug Administration guidelines:

- System designed for GMP operation and validation
- Audit trail to support CFR 21 part 11 compliance and performer/verifier traceability for GMP operations and compliance
- Materials and gaskets in accordance with USP Class VI
- Compliance with ASME-BPE regulations
- LEWA hygienic metering pumps are certified in accordance with the European Hygienic Engineering & Design Group (EHEDG)
- CE conformity

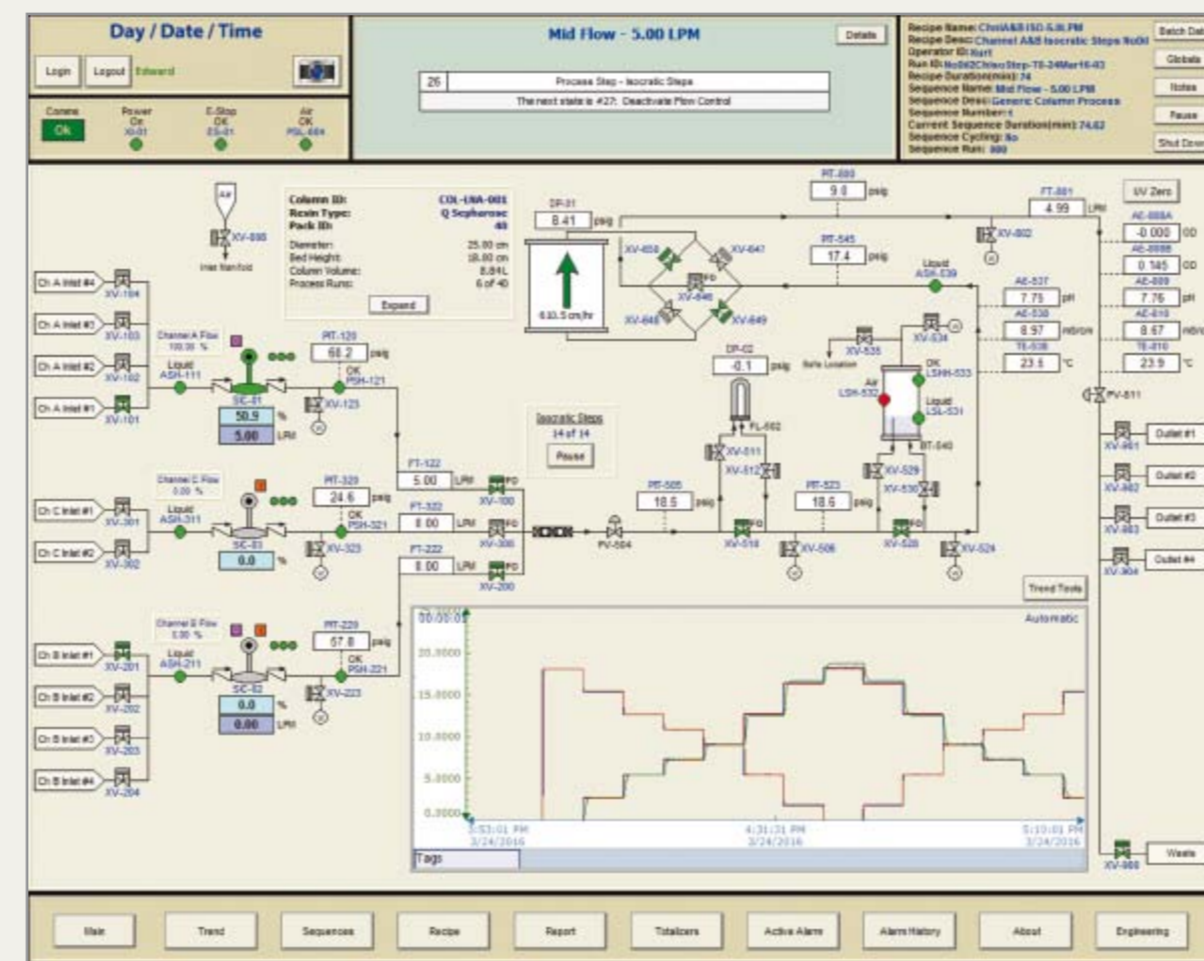

The user interface of LEWA EcoPrime was developed for GMP pilot and process environments.

LEWA EcoPrime Twin. Innovation for multi-column chromatography.

Introducing LEWA EcoPrime Twin

Building on the LEWA EcoPrime LPLC platform, LEWA is now introducing the most advanced and yet easy-to-use twin column system for continuous chromatography on the market. LEWA EcoPrime Twin was developed for use in the GMP environment and is based on the patented twin column technology for continuous chromatography from ChromaCon AG.*

LEWA and ChromaCon provide systems for next-generation continuous downstream processes – from laboratory scale to production scale. Ask your sales contact for more detailed information.

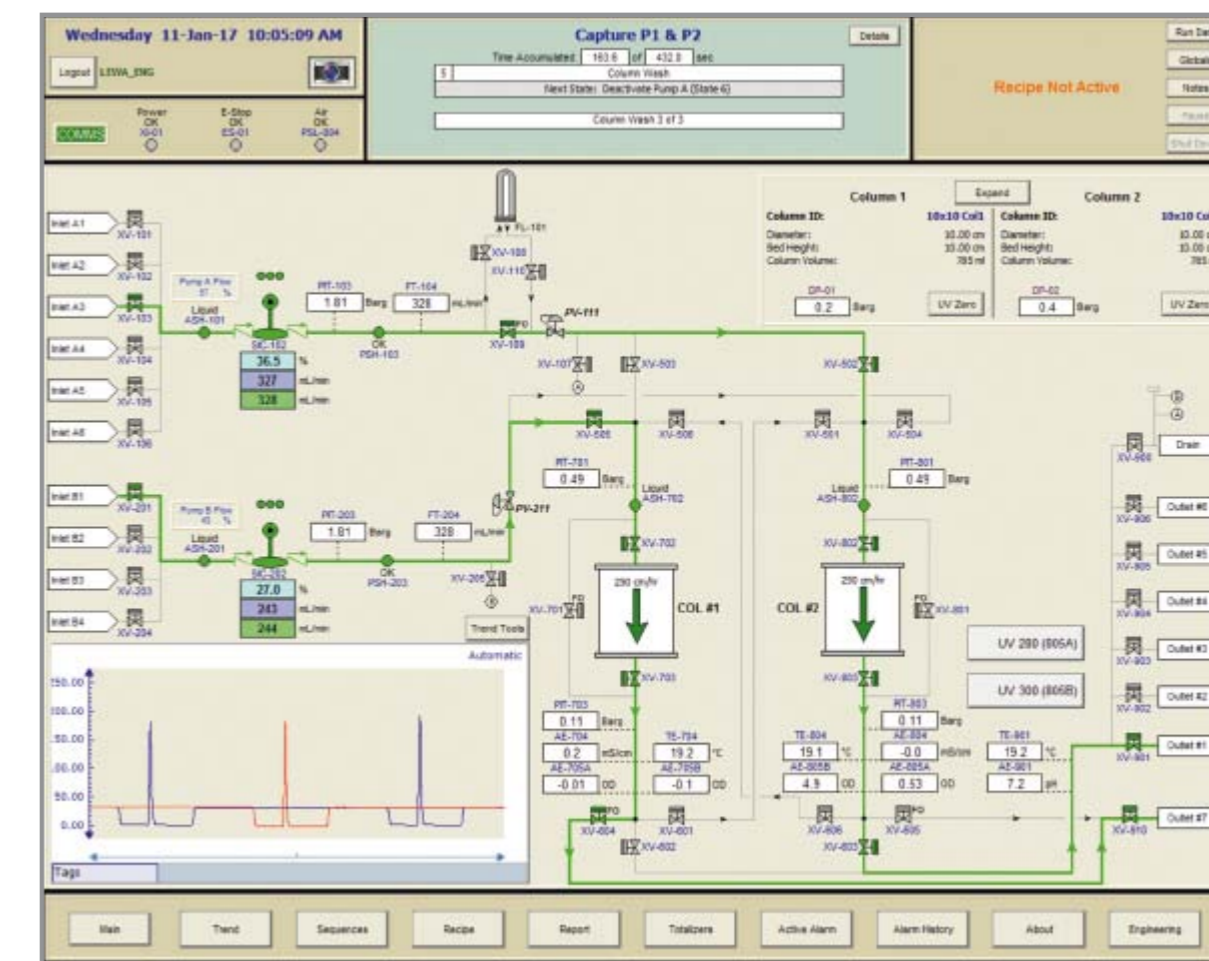

* Operated under license of ChromaCon AG.

Creating Fluid Solutions. For more value created.



Technical consulting

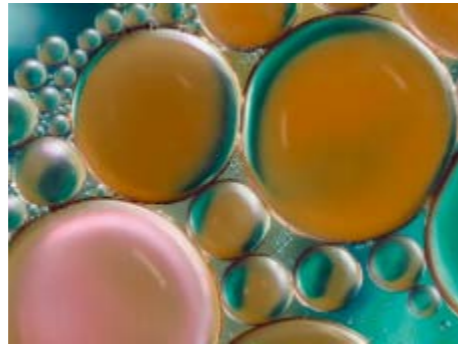

Fluid and process
engineering tests



Lifecycle concepts and
energy optimization



Process automation



Pulsation studies and
pipeline calculations



System layout and integration



Creative development
and refinements



Commissioning and
maintenance service



Spare part and service concepts

Creating Fluid Solutions.

Driven by our commitment, our trendsetting products and innovative technologies have set benchmarks for metering systems and diaphragm pumps for over 60 years. We solve complex tasks from a single source. This ranges from standard and customized system engineering, global project management, individual pump design and pretesting to commissioning and maintenance on site. Our consistent drive always to develop the best solutions for the customer provides you with a higher productivity and visible added value.

Your local representative:



LEWA GmbH
Ulmer Str. 10
71229 Leonberg
Germany

Telephone +49 7152 14-0
Fax +49 7152 14-1303
sales@lewa.de
www.lewa.com